

“POWER QUALITY IMPROVEMENT USING 5-LEVEL FLYING CAPACITOR MULTILEVEL CONVERTER BASED DYNAMIC VOLTAGE RESTORER FOR VARIOUS FAULTS”

Mr. Suhas R. Patil 1, Prof. Shrivankumar Akireddy
1,2 Electrical Engineering Department
Fabtech Technical Campus Sangola, Solapur, India

ABSTRACT:

This paper presents the use of five level flying capacitor multilevel converters based dynamic voltage restorer (DVR) on power distribution system to decrease the power-quality disturbances in distribution system, such as voltage imbalances, harmonic voltages, and voltage sags. This DVR based five multilevel topology is suitable for medium-voltage applications and operated by the control scheme based on the so called repetitive control. The organization of this paper has been divided into three parts; the first one eliminates the modulation high-frequency harmonics using filter increase the transient response. The second one deal with the load voltage; and the third is flying capacitors charged with balanced voltages. The MATLAB Simulation results are presented to illustrate and understand the performances of DVR in supporting load voltage.

INDEX TERMS -Dynamic voltage restorer (DVR), flying capacitor multilevel converter, power quality (PQ), Total harmonic distortion (THD), repetitive control, voltage sags, Voltages swell.

I. INTRODUCTION

One of the major concerns in electricity industry today is power quality problems to sensitive loads. The disturbances introduced by nonlinear loads and the rapid growth of renewable energy sources. Majority of power quality problems also affect the end user. The DVR is promising and effective device for power quality enhancement due to its quick response and high reliability.[1]Multilevel converters based on DVR are the most accepted topology in industry for medium voltage (MV) applications such as medium voltage drive systems. Which allow high power-handling capability with lower harmonic distortion and lower switching power losses than the two- level converter. Recently, modular multilevel converters topology has been reported as an alternative to conventional multilevel inverters in medium and high voltage applications. [2]-[3]It is able to overcome most of difficulties of conventional multilevel inverter and provides new set of features such as – Modular construction; it has fault management capability and better fault ride through capability, with increased number of levels, it generates high voltage with reduced voltage stress on switching device, and extremely low total harmonic distortion. (THD)

The balancing of FC voltages is quite important and dictates both the safe and efficient operation of the converter. There are three types of multilevel converter topologies namely, the neutral point- clamped (NPC) converter, the flying capacitor (FC) converter, and the cascaded converter with separate dc voltage sources (also called H-bridge converter).[6]-[7]The FC converter has attracted a great deal of interest in recent years mainly due to a number of advantageous features.

For instance, it seems that the extension of the converter to higher than three levels is possibly easier than the NPC alternative in commercial applications. This paper focuses on the design of a closed-loop control system for a DVR by using a five-level flying capacitor converter, based on the so-called repetitive control.

II. CONFIGURATION OF THE DVR

A. FIVE LEVEL FC

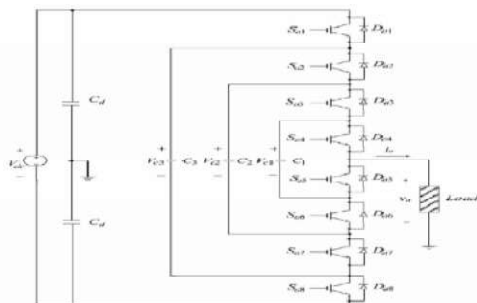

Fig.1. Phase-leg of five-level FC multilevel converter

Table 1: Switching states

Vo	Switching States			
	Sa1	Sa2	Sa3	Sa4
$+V_{dc}/2$	1	1	1	1
$+V_{dc}/4$	1	1	1	0
	1	0	1	1
	0	1	1	1
0	1	1	0	0
	1	0	1	0
	0	1	1	0
	1	0	0	1
	0	1	0	1
$-V_{dc}/4$	0	0	1	1
	1	0	0	0
	0	1	0	0
	0	0	1	0
$-V_{dc}/2$	0	0	0	1
	0	0	0	0
	0	0	0	0

The diode in the diode clamped topology can be replaced by clamping capacitors or floating capacitors to clamp the voltage such topology is called flying capacitor multilevel converter. They are called Flying Capacitor Multilevel Inverter, because the capacitors float with respect to earth's potential. [8] This topology is relative new as compared to H-bridge converter and neutral point-clamped (NPC) converter. Fig.1. shows that the Phase-leg of five-level FC multilevel converter and switching table. This topology consists of diodes, capacitors and switching devices. Each leg consists of switching devices which are generally transistors. Regarding the five-level topology shown in Fig. 1 the flying capacitors C_1, C_2 and C_3 are charged to, $3V_{dc}/4, V_{dc}/2,$ and $V_{dc}/4$ respectively. Therefore, each switch must block only a voltage value equal to $V_{dc}/4$ allowing the use of switches with lower-rated voltage compared with those in a conventional two-level converter. There are several switching combinations for the same given output voltage, which is known as switching redundancy [7].

A. DYNAMIC VOLTAGE RESTORER (DVR) CONNECTION SYSTEM:

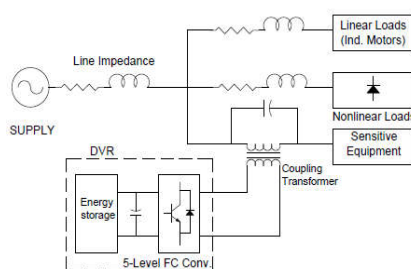

Fig. 2: Basic scheme of the system configuration with the DVR.

DVR is a Custom Power Device used to eliminate supply side voltage disturbances. DVR also known as Static Series Compensator maintains the load voltage at a desired magnitude and phase by compensating the voltage Sags/swells and voltage unbalances presented at the point of common coupling.[1] The DVR consists of a five-level flying-capacitor voltage-source converter and energy storage which provides the necessary voltage to the dc link. [8] The series connection of the DVR is achieved by means of a coupling transformer. A passive LC filter has been used to filter out the high harmonics generated by the PWM process.

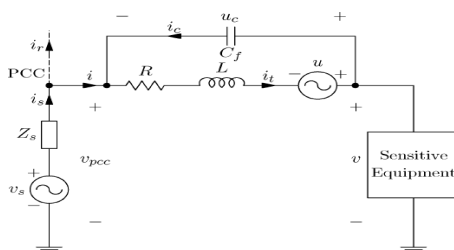

Fig. 3: Equivalent circuit for the DVR connection system.

The equivalent circuit for the one-line system in Fig. 2 is depicted in Fig. 3, where V_s is the supply voltage, Z_s models the line impedance, i_s is the current injected by the supply, which splits at the PCC into the current flowing through the sensitive equipment i and the current injected into the load i_r .

The voltage V_{cc} is the measured voltage at the PCC, u stands for the DVR voltage which has been modeled as an ideal voltage source, the parameters R and L are the resistance and the leakage inductance, respectively, of the coupling transformer whereas C_f is the capacitor used together with the coupling-transformer leakage inductance to filter out the high-frequency harmonics. Finally, uc and v are the voltages across the filter capacitor and the measured voltage across the sensitive equipment, respectively.

The equation of the sensitive-equipment voltage v can be written as:

$$vt = vpcc(t) + (t) \dots\dots\dots(1)$$

With the following state-variable model for the coupling transformer and the capacitor set:

$$\frac{d}{dt} \begin{bmatrix} it(t) \\ uc(t) \end{bmatrix} = \begin{bmatrix} \frac{-R-1}{L} & \frac{-1}{L} \\ \frac{1}{Cf} & 0 \end{bmatrix} \begin{bmatrix} it(t) \\ uc(t) \end{bmatrix} + \begin{bmatrix} \frac{1}{L} & 0 \\ 0 & \frac{1}{Cf} \end{bmatrix} \begin{bmatrix} u(t) \\ i(t) \end{bmatrix} \dots\dots\dots(2)$$

Where the state variables are $i_t(t)$ and $u_c(t)$, the control input is u_t and i_t is a disturbance input.

III. CONTROL SYSTEM AND MODULATION STRATEGY

A. REPETITIVE CONTROL

The repetitive control is a control scheme for single input single-output continuous system to achieve high accuracy for tracking periodic reference, which was proposed by Inoue etc. in the 1980's. If the sinusoidal signal is superposed of one harmonic frequency, one PR controller would be needed but if the signal is superposed of infinite harmonic frequencies, infinite PR controller would be needed. Repetitive controller is able to compensate all of harmonics only with a feedback of delay in its scheme Repetitive Control is the control technique based on the internal model principle used when you need to follow or rejects periodic signals. A repetitive control system usually contains element shown below:

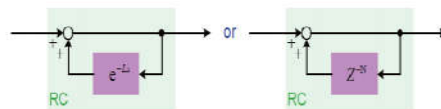

It is used specifically to handle periodic signals/operations; If properly designed, a repetitive control system can track periodic reference and reject periodic disturbance without steady-state error A method introduced in 1980s by a group of Japanese scholars, now has been widely applied in many different engineering practices.

B. CONTROL SYSTEM FOR THE OUTPUT VOLTAGE OF THE LC FILTER

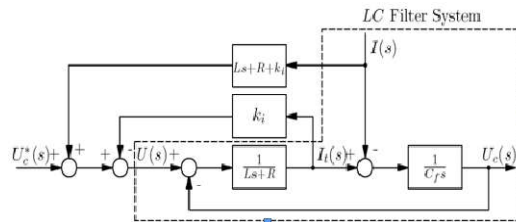

Fig. 4: Filter output voltage control scheme.

The structure of this control scheme can be seen in Fig. 4. System is a second-order filter with natural frequency $\omega_n = 1/\sqrt{LCf}$ and damping coefficient, $\zeta = R/2 \cdot \sqrt{Cf/L}$. This filter exhibits a large resonance since the resistance R usually has a very small value and, therefore, the damping coefficient is also very small. To overcome this problem, closed-loop control of the filter output voltage is required. A proportional state-feedback controller plus a feed forward term are proposed for (2), with the following structure:

$$u(t) = - [K_i K_u] \begin{bmatrix} i(t) \\ u_c(t) \end{bmatrix} + u_c^*(t) + h(i(t)) \dots \dots \dots (3)$$

Where K_i and K_u i. e. K is the feedback-gain matrix, $u_c^*(t)$ is the reference value, and the feed forward term $h(i(t))$ is a function $i(t)$ of which will be calculated to cancel out the effect of the disturbance $i(t)$ on the voltage $u_c(t)$. The gain matrix here has been designed in order to obtain a second-order closed-loop system with natural frequency $\omega_c = 1/\sqrt{LCf}$ and damping coefficient $\zeta_c = 1$ which means that the closed-loop system has two identical real poles equal to $S_{1,2} = -1/\sqrt{LCf}$ and the time response will not exhibit any overshoot.

C. FLYING-CAPACITOR VOLTAGE CONTROL

In theory, the phase-shifted PWM method is able to balance the flying-capacitor voltages. Nevertheless, in practical implementations, there may be factors, such as asymmetrical conditions, different characteristic of power switches, etc, that produce voltage imbalances in the flying capacitors. For that reason, a control scheme, which guarantees the balance of the FC voltage, is required. Voltage control is based on a closed-loop control scheme which corrects, for each switch, the modulating signal by adding a square-wave in order to increase or decrease the capacitor voltages.

D. PHASE-SHIFTED PULSE WIDTH MODULATION

Several modulation methods have been used in multilevel converters according to the switching frequency. In this paper, the well-known phase-shifted PWM method has been used since its implementation is simple and provides a certain degree of flying-capacitor voltage balance.[7]

IV. MATLAB CIRCUIT AND SIMULATION

A. MATLAB CIRCUIT:

Matlab circuit with 5 flying capacitor converter for power quality improvement as shown in following figure.

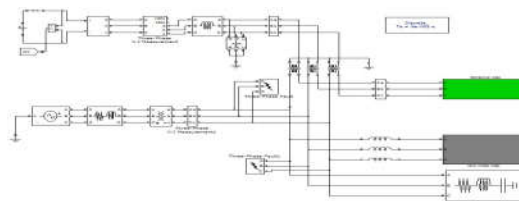

Fig 5: Matlab circuit with 5 flying capacitor converter

B.SIMULATION RESULTS:

The test system shown in Fig. 5 is used to carry out a comprehensive simulation scenario where the multilevel DVR and its control system show their worth. The following sequence of events is assumed to take place: 1) the nonlinear load is connected at time $t = 0$ s and the charging of the flying capacitors also starts at this point in time, a process that is fully completed at time $t = 0.6$ s; 2) At this point, the whole control system is activated and the DVR is connected to the grid together with the inductive-resistive load (sensitive load); 3) in the time period 0.7–1.1s, induction motor 1 is assumed to be connected with a constant rotor speed of 0.98 p.u.; 4) from $t = 0.8$ s to 1.1s, a two-phase-to-ground short-circuit fault is applied at the PCC via a 1.8- resistor 5) the nonlinear load is disconnected at 1.3s and, at this point in time, a second short-circuit fault applied at the PCC takes place; this time, there is a three-phase-to-ground fault, with a duration of 200ms. The total simulation time is 1.6s.

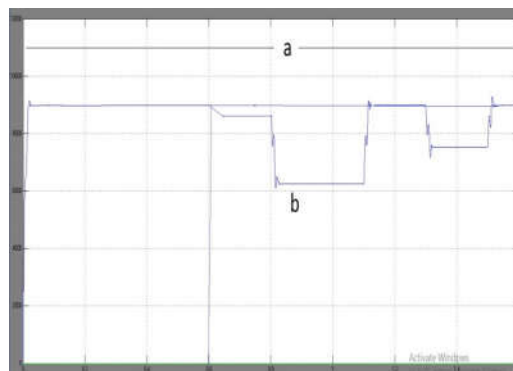

Fig. 6. rms voltage. (a) Across the sensitive equipment. (b) At the PCC.

Fig. 6 (a) and (b) shows the rms voltages of phase A at the point where the sensitive load is connected and at the PCC, respectively. The two-phase-to-ground short-circuit fault produces a 30% voltage sag in the two affected phases in the time period 0.8–1.1 s. Also notice the minor voltage dip caused by induction motor 1 in the period 0.7–0.8 s. It is clear that in the period 0.8–1.1 s, the induction motor contributes to some minor extent to the voltage sag but, by and large, the major contributor to the sag is the short-circuit fault. Fig. 7 shows the unbalanced line-to-line voltages at the PCC: the three voltage waveforms have different amplitudes and they also contain harmonic voltages caused by the rectifier.

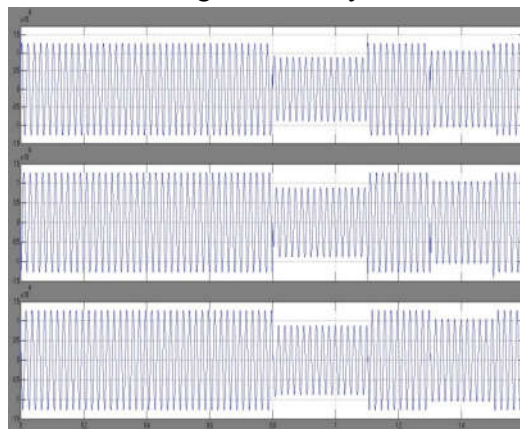

Fig. 7 Line-to-line voltages at the PCC in kilovolts (a) V_{pccab} , (b) V_{pccb} , and (c) V_{pcca} . ($0.7 < t < 1.2$)

Fig. 8 shows the line-to-line voltage at the PCC and across the sensitive load. Since the fault is symmetrical, only one of the line-to-line voltages has been plotted for each case. The rms value of the line-to-line voltage at the PCC is 7.7 kV (70% of its rated value) with no voltage distortion.

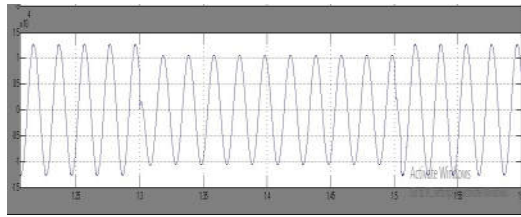

Fig. 8: Line-to-line voltage at PCC ($1.26s < t < 1.54 s$)

IV.CONCLUSION

In this paper DVR based on a five level flying-capacitor converter operated by a repetitive-control scheme. This control structure simultaneously cancels out voltage sags, voltage imbalances, and voltage harmonics other than high frequency switching harmonics. The control system is split into three subsystems: the first one works to eliminate the resonance peak of the filter used in the converter output voltage; while the second one is the repetitive control, which ensures a fast transient response and zero-tracking error in steady-state for any sinusoidal reference and for any sinusoidal disturbance whose frequencies are an integer multiple of the fundamental frequency. Finally, the third subsystem maintains constant, balanced voltages in the flying capacitors. The control system, together with the DVR, has been implemented in MATLAB Comprehensive simulation results using an MV test system show the DVR's excellent performance and the control system in order to protect sensitive equipment from PQ disturbances.

REFERENCES

- [1] M. H. J. Bollen, *Understanding Power Quality Problems: Voltage Sags and Interruptions*. Piscataway, NJ: IEEE Press, 2000.
- [2] V. Immanuel and G. Yankanchi, "A waveform synthesis technique for voltage sag compensation using dynamic voltage restorer (dvr)," in *Proc. IEEE Power Eng. Soc. General Meeting, Jun. 2006*, pp. 1–7.
- [3] N. G. Hingorani, "Introducing custom power," *IEEE Spectr.*, vol. 32, no. 6, pp. 41–48, Jun. 1995.
- [4] Z. Changjiang, A. Arulampalam, and N. Jenkins, "Four-wire dynamic voltage restorer based on a three dimensional voltage spacevector pwm algorithm," *IEEE Trans. Power Electron.*, vol. 18, no. 4, pp. 1093–1102, Jul. 2003.
- [5] L. Xu and V. G. Agelidis, "Flying capacitor multilevel pwm converter based upfc," *Proc. Inst. Elect. Eng., Electr. Power Appl.*, vol. 149, no. 4, pp. 304–310, Jul. 2002.
- [6] E. Acha, V. G. Agelidis, O. Anaya, and T. J. E. Miller, *Power Electronic Control in Electrical Systems*. Oxford, U.K.: Newnes, 2001.
- [7] C. Feng, J. Liang, and V. G. Agelidis, "Modified phase-shifted pwm control for flying capacitor multilevel converters," *IEEE Trans. Power Electron.*, vol. 22, no. 1, pp. 178–185, Jan. 2007.
- [8] *Five Level Flying-Capacitor Multilevel Converter Using Dynamic Voltage Restorer (DVR)*- K. Ramakrishna Reddy & G. Koti Reddy
- [9] J. Arrillaga, Y. H. Liu, and N. R. Watson, *Flexible Power Transmission. The HVDC Options*. Chichester, U.K.: Wiley, 2007.